



Hahn Türband 4 AT Halbmaß Null

- D** Universalbänder für Metalltüren
- F** Paumelles universelles pour portes en métal
- GB** *Universal hinges for metal doors*



Einbauanleitung · Installation instructions · Montage-instructies

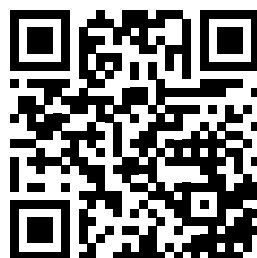

Alle Dr. Hahn
Anleitungen jetzt
als APP erhältlich:
[www.dr-hahn.eu/
anleitungen](http://www.dr-hahn.eu/anleitungen)



Einbauanleitung
Notice de montage
Installation instructions

Abbildung DIN links
 Figure DIN gauche
 Figure shows DIN left

Montage des Türbands · Montage de la paumelle · Installing the hinge

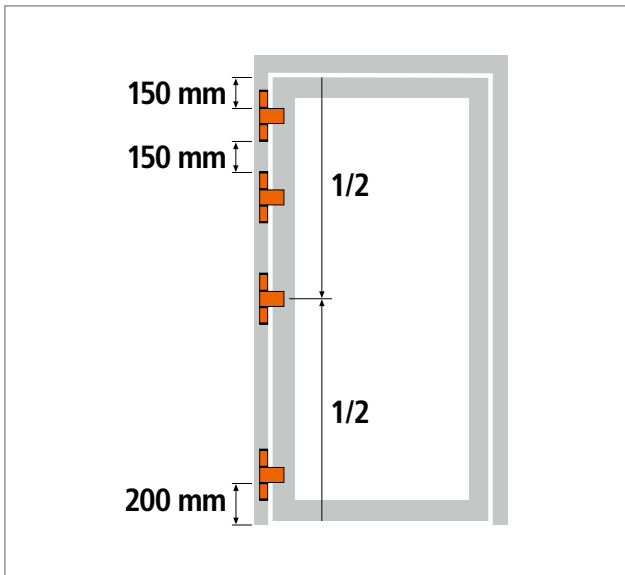

Wir empfehlen beim Einsatz von Drehflügelantrieben, kräftigen Schließmitteln, Türstoppnern oder starker Beanspruchung in einem Abstand von 150 mm unterhalb des oberen Türbandes ein weiteres drittes Band anzuordnen. Wir beraten Sie gerne.

Si vous utilisez un ouvre-porte automatique, un ferme-porte puissant, une butée de porte ou si votre porte est soumise à un grand trafic, nous préconisons le montage d'une troisième paumelle à 150 mm sous la paumelle du haut. Nous vous conseillons volontiers.

With automatic swing door operator, heavy closing devices, doorstops or heavy operational demand, we recommend placing a further 3rd hinge at a distance of 150 mm beneath the top hinge. Please contact us.

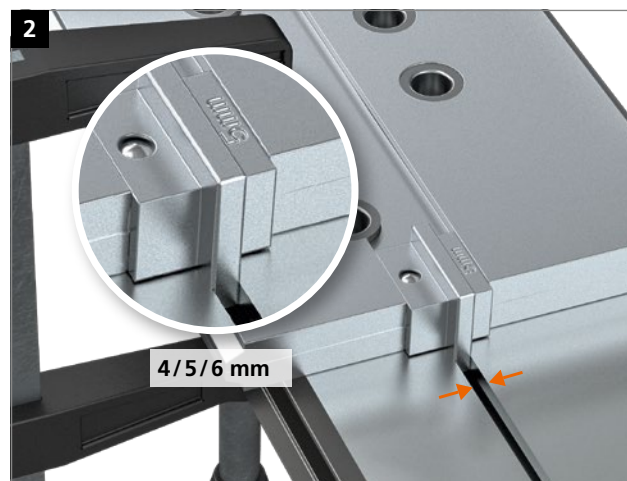

DIN links/DIN rechts beachten.
 Veillant au montage gauche/ droite. Mind DIN left/right.

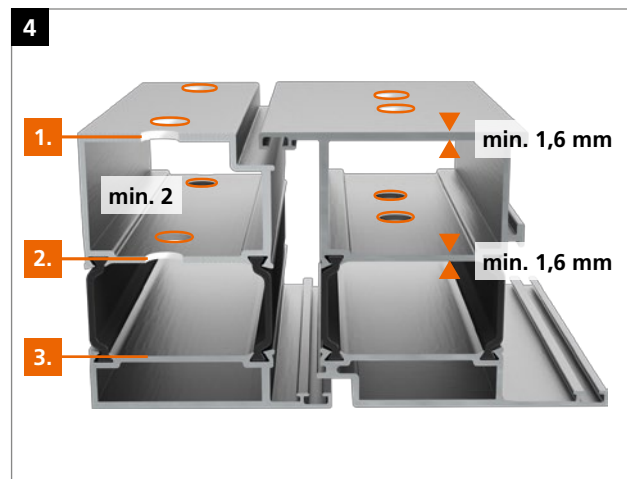
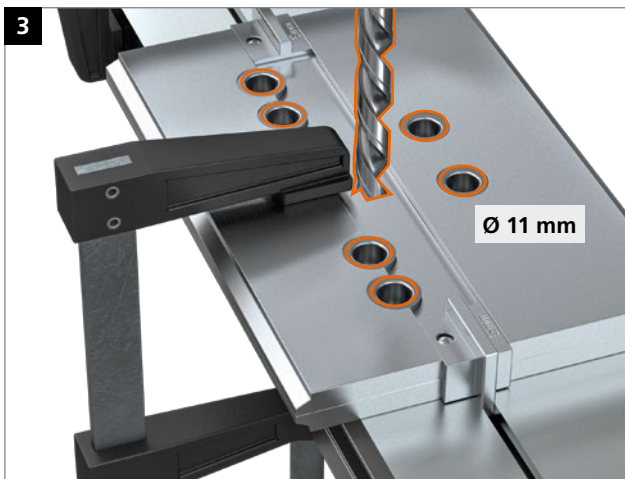



Montage des Türbands · Montage de la paumelle · Installing the hinge

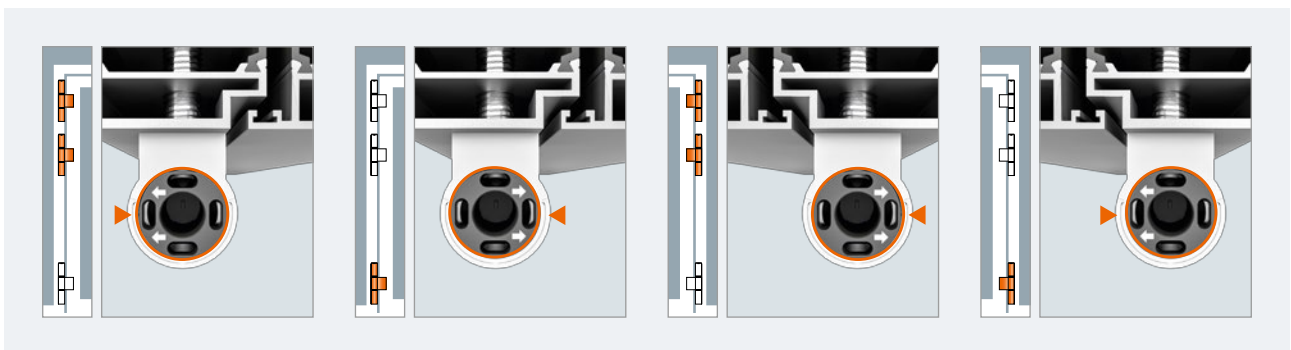
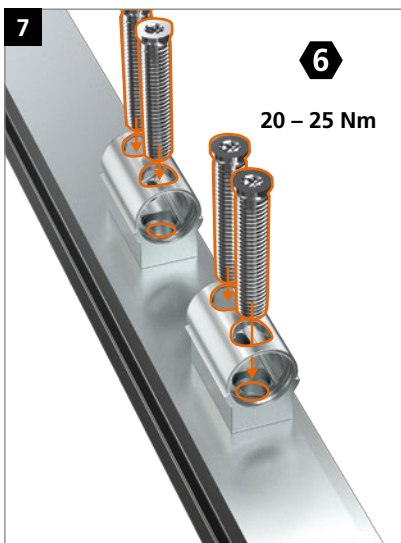
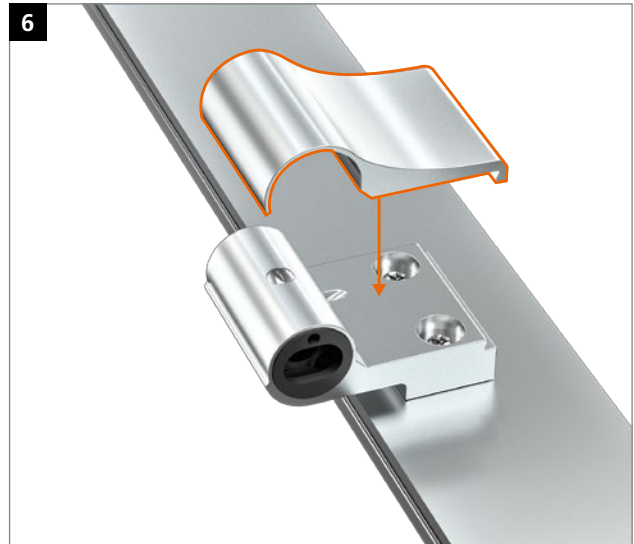
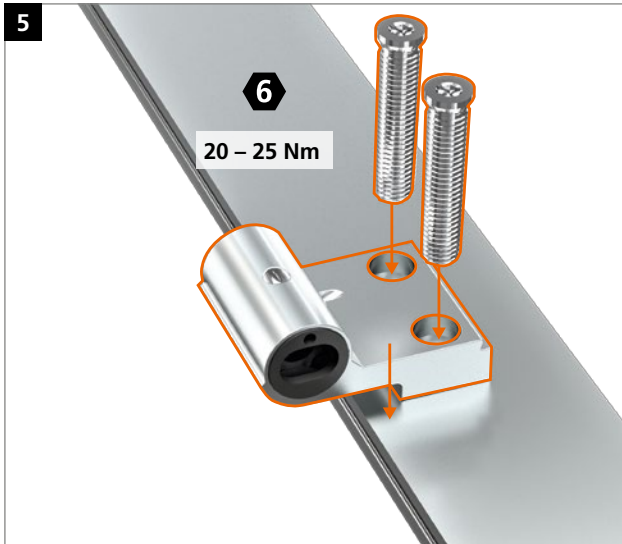

Lagerbushse aus wartungs-
freiem Kunststoff
– keinesfalls schmieren!

Douille en matière plastique
ne requérant aucun entretien
– ne graisser en aucun cas !

Bearing bushes made
of maintenance-free PVC
– do not lubricate!

Einbauanleitung
Notice de montage
Installation instructions

Montage des Türbands · Montage de la paumelle · Installing the hinge

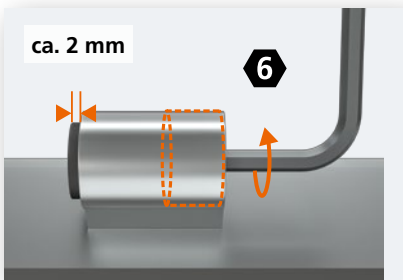
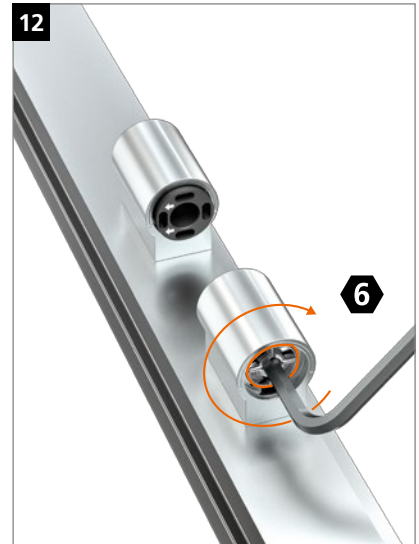
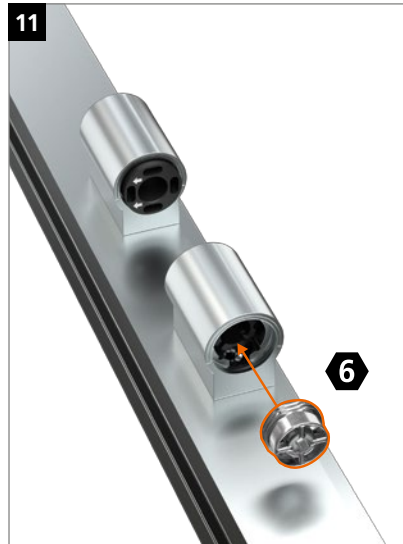
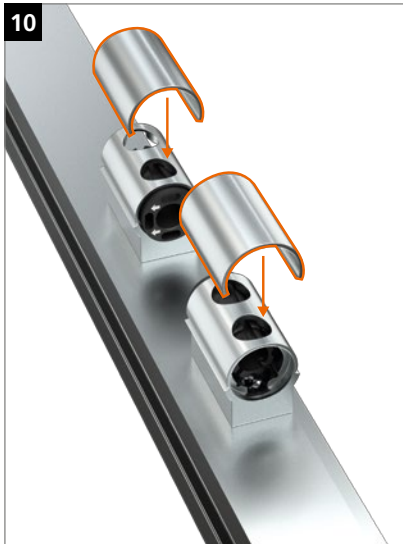

Hebespindel einschrauben,
 bis Lagerbuchse in Null-Stellung.
 Visser la broche de soulèvement
 jusqu'à la position zéro de la douille.
 Screw-in lifting and lowering spindle
 until bearing bushing is in 0 position.

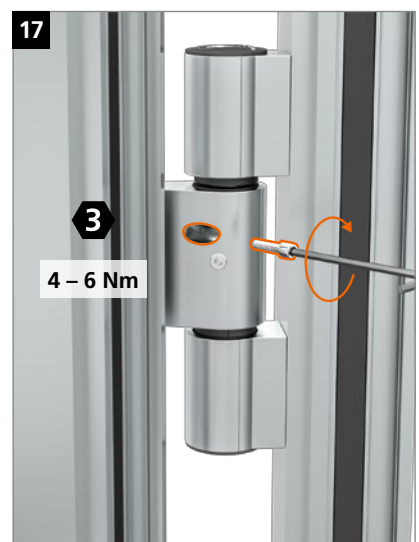

Einstellanleitung
Notice de réglage
Adjustment instructions

Verstellung der Bänder nur durch im
 Türenbau erfahrene Fachhandwerker.

Réglage et montage des paumelles
 uniquement par des professionnels qualifiés.

Adjustment and regulation only to be
 done by an experienced tradesman.



Dichtungsdruck verstellen · Régler la pression du joint d'étanchéité · Adjusting the sealing pressure

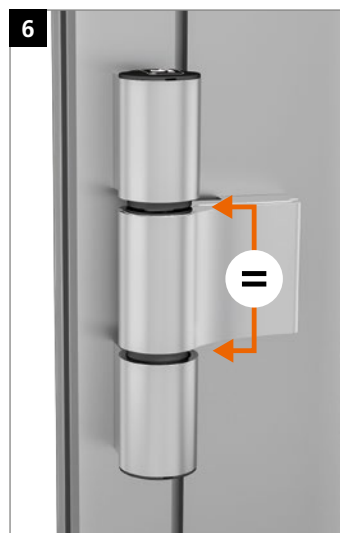
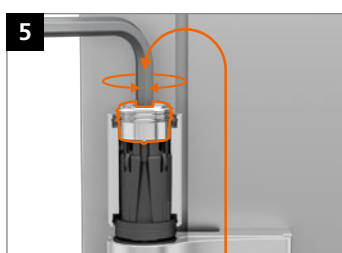
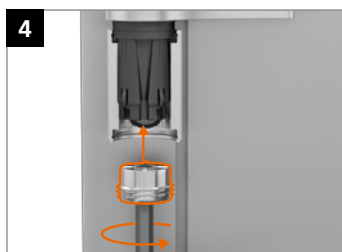
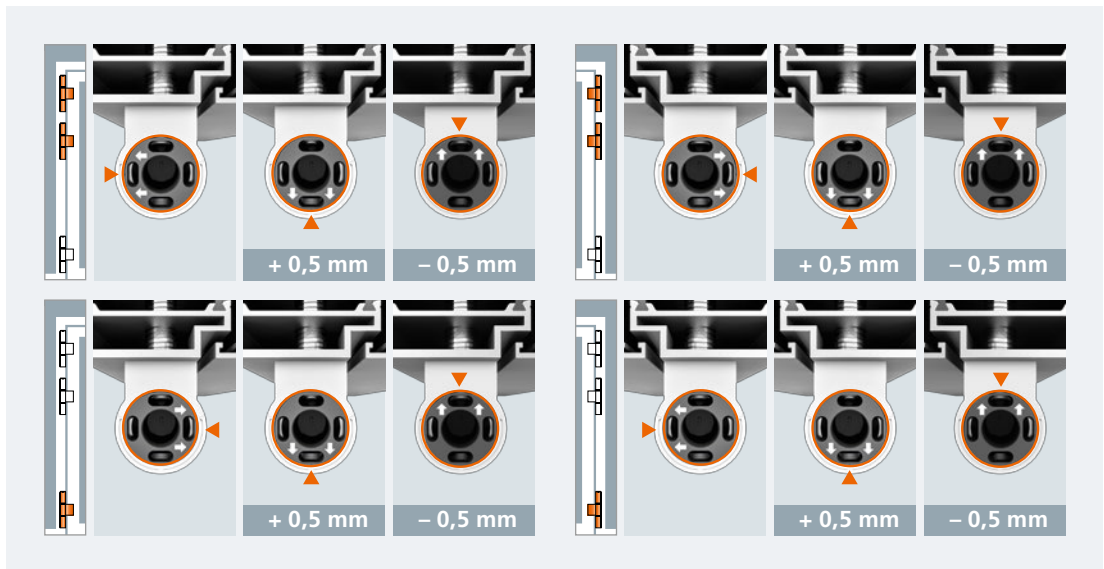
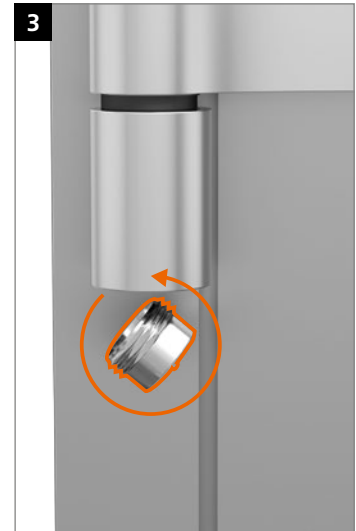
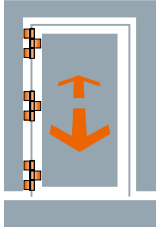

Einstellanleitung
Notice de réglage
Adjustment instructions

Verstellung der Bänder nur durch im
 Türenbau erfahrene Fachhandwerker.

Réglage et montage des paumelles
 uniquement par des professionnels qualifiés.

Adjustment and regulation only to be
 done by an experienced tradesman.

Höhenverstellung · Réglage en hauteur · Adjusting the height

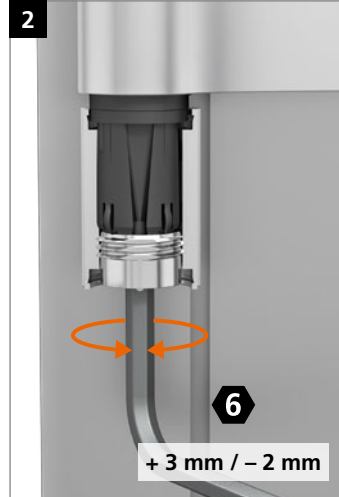
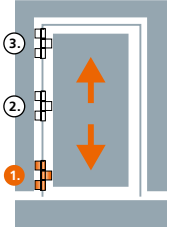

Horizontalverstellung · Réglage horizontal · Horizontal adjustment

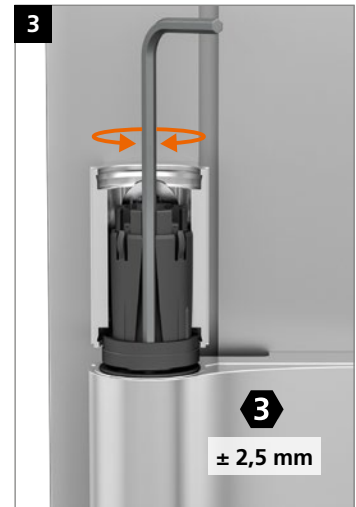
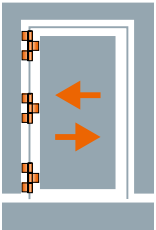

Wichtig:
 Gewindestift festziehen.

Important :
 Serrer la vis pointeaux.

Important:
 Tighten the setscrew.

Verstellung der Bänder nur durch im
Türenbau erfahrene Fachhandwerker.

Réglage et montage des paumelles
uniquement par des professionnels qualifiés.

Adjustment and regulation only to be
done by an experienced tradesman.



Demontage an der Baustelle · Démontage sur le chantier · Disassembly on site

